

TC-NCL222C

2MP IR Dome Camera

Tiandy



Features

- Up to 1920X1080@20fps
- S+265/H.265/H.264/M-JPEG Codec
- Min. Illumination Color: 0.05 Lux, B/W: 0.01Lux, 0 Lux with IR
- Smart IR, IR Range: 30m
- Operating Conditions -35℃ ~ 60℃ (IR OFF) / -30℃ ~ 40℃ (IR ON), 0 ~ 95% RHG
- PoE, IP66

Dimensions

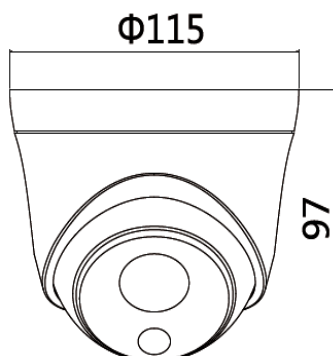

Camera	
Image Sensor	1/2.7" CMOS
Core Processor	ARM9 Architecture
Operating System	Embedded Linux
Signal System	PAL/NTSC
Min. Illumination	Color: 0.05Lux B/W: 0.01Lux
Shutter Time	1s to 1/100,000s
Lens	2.8mm
Auto Iris	N/A
Wide Dynamic Range	100dB
Digital Noise Reduction	3D DNR
Compression Standard	
Video Compression	S+265/H.265/H.264/M-JPEG
Video Bit Rate	32Kbps~8Mbps
Image	
Max. Image Resolution	1920x1080
Frame Rate	PAL:1080p@20fps, 960p@25fps, 720p@25fps, D1@25fps NTSC:1080p@20fps, 960p@30fps, 720p@30fps, D1@30fps
couple Stream	Mainstream:1080P(1920*1080) Substream:4CIF (704*480)
Image Settings	Brightness, Saturation, Contrast, Flip Mode Adjustable by Client Software or Web Browser
HLC	Y
Smart Defog	Y
OSD	16×16, 32×32, 48×48, Size Letters Such as Week, Date, Time, Total 1 Regions
Network	
Video Analytics	Tripwire/Perimeter
Browser	built-in web server
NTP	Y
Alarm Trigger	Motion Detection/IP Conflict/MAC Conflict/Mask Alarm
Protocols	TCP/UDP/HTTP/MULTICAST/UPnP/DHCP/DDNS/FTP/NTP/RTSP/SNMP
User Permission	4 Level/8 Users
System Compatibility	ONVIF (Profile S) , P2P
Interface	
Audio Input	N/A
Audio Output	N/A
Communication Interface	1-ch RJ45 10M / 100M Ethernet Interface
Alarm Input	N/A
Alarm Output	N/A
Video Output	N/A
General	
Language	English, Simplified Chinese, Traditional Chinese, Spanish, Italian, Korean, Turkish, Russian, Thai, polish, French
Operating Conditions	-35℃~60℃, 0~95% RHG
Power Supply	DC 12 V ± 25%, POE
Power Consumption	Max. 3W(IR OFF) (ICR Instant Switch 5.5W)
Impact Protection	IP66
IR Range	30m
Dimensions	115mm(diameter)*97mm(height)
Weight	0.5KG

* The latest product information / specification can be found at <http://en.tiandy.com/>

